

NOTE: LED= Light Emitting Diode

LABELING EXPLANATION:

- X: Self contained
- 1: Maintained (*)
- A: Including test device
- E: With non-replacable lamp(s) and/or battery
- F: Automatic test gear complying with IEC 61347-2-7 denoted EL-T
- 60: 1 hour duration
- 180: 3 hours duration
- 480: 8 hours duration

X1AEF180

(*) **Maintained operation:** The luminary lights its illumination source, when it is powered by the mains power supply or not.

Non Maintained operation: The luminary lights its illumination source, only in mains power supply's failure.

ATTENTION!!!

 The light source of this luminary is not replaceable when the light source reaches its end of life the whole luminaire shall be replaced.

Technical Characteristics

KLIN-20/ST	
MAINS VOLTAGE	220-240V AC / 50-60Hz
MAXIMUM POWER CONSUMPTION	3.9W/4.4VA
BATTERY (Ni-Mh)	3.6V/1.5VA
BATTERY PROTECTION	Overcharging and deep discharging protection
INDICATIONS	Charge LED, Lamp fault LED, Battery fault LED / Test button
RECHARGING TIME	24 hours
MINIMUM EMERGENCY DURATION	1 h / 3 h / 8 h manually selected (default 3h)
LIGHT SOURCE INTENSITY (230V)	80lm
LIGHT SOURCE INTENSITY (EMERGENCY)	1 h : 250lm / 3 h : 110lm / 8 h : 15lm
DEGREES OF COVER PROTECTION	IP44
PRODUCED IN ACCORDANCE WITH	EN 60598-1, EN 60598-2-22, EN 55015 EN 61547, EN 61000-3-2, EN 61000-3-3
OPERATION TEMPERATURE RANGE	5 to 40 °C
RELATIVE HUMIDITY	up to 95%
CONSTRUCTION MATERIALS	PC
EXTERNAL DIMENSIONS (LXWXH)	260x35x60mm
TYPICAL WEIGHT	405gr.
GUARANTEE	3 years (1 year for the battery)

LED Characteristics

KLIN-20/ST	
MANUFACTURER	Olympia Electronics S.A.
MODEL NUMBER	2711195
VOLTAGE RANGE	11.2-13.2V DC
NOMINAL POWER	0.72W
CONNECTIONS	Built-in main board
TEMPERATURE (tc)	45 °C max. across the board

Warranty

Olympia Electronics guarantees the quality, condition and operation of the goods. The period of warranty is specified in the official catalogue of Olympia Electronics and also in the technical leaflet, which accompanies each product. This warranty ceases to exist if the buyer does not follow the technical instructions included in official documents given by Olympia Electronics or if the buyer modifies the goods provided or has any repairs or re-setting done by a third party, unless Olympia Electronics has fully agreed to them in writing. Products that have been damaged can be returned to the premises of our company for repair or replacement, as long as the warranty period is valid.

Olympia Electronics reserves the right to repair or to replace the returned goods and to or not charge the buyer depending on the reason of deflection. Olympia Electronics reserves the right to charge or not the buyer the transportation cost.



72nd km. O.N.R. Thessaloniki-Katerini
P.C. 60300 P.O. Box 06 Eginio Pierias Greece
www.olympia-electronics.gr
info@olympia-electronics.gr



KLIN-20/ST

KLIN-20/ST

**SELF TESTING MAINTAINED/NON-MAINTAINED
EMERGENCY LUMINAIRE**



**Thank you for your trust in our products
Olympia Electronics - European manufacturer**

Package contents

1	Luminaire
1	Wall mounting accessories
1	Ceiling mounting accessories
1	Manual

General

This luminaire is used indoors (ta 40°C) where emergency light is needed. Each luminaire must be permanently connected to mains power supply. In normal operation the led strip lights and the battery is charging. In case of a mains power supply failure the luminaire will light the led strip automatically in emergency mode (powered by its battery). When the mains power supply is restored the device turns to normal operation.

Autonomy duration selection

The user can select one of the 3 available minimum autonomy durations 1 hour, 3 hours and 8 hours. The selection must be done while the luminaire is disconnected from AC and battery supplies. The selection is achieved through Switches 2 & 3 of DS1 according to step 5 in page 3. Switch 1 is not used.

Technical label installation

Two additional labels are included in the package. one for 1 hour duration (60) and one for 8 hour duration (480). Depending on the selected duration, the installer must cover the default 3 hour (180) printing with one label that has the required duration. Please take notice of the orientation of the label.

Battery charging

The battery charging is completely controlled by a microprocessor and is protected from complete discharge and over charge.

Battery cut-off

The luminaire enters in this operation when the mains power supply fails and battery has lost its energy. During this operation the luminaire enters the idle state and battery consumption is negligible, in order to be protected from deep discharge.

Manual test for emergency operation and light source.

The manual test can be conducted only if the mains power supply and the battery is connected:

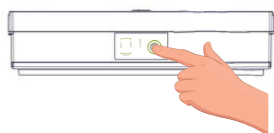

During the Test the lamp fault LED blinks.

Manual autonomous test

A duration test can be conducted if the TEST button is pressed from 5 to 10 seconds. The luminaire enters emergency mode, the charge LED is turned OFF and the Battery Fault led starts to blink. The test is conducted until the battery is depleted. If at the end of the test the autonomy is low then the Battery Fault LED will be ON. If the result of the test is good then the luminaire enters

charging mode and the Charge led starts to blink until the batteries are fully charged.

Automatic operational test

This test includes all the operations that provide the manual test and is conducted automatically every 15 days. In order to be performed, the mains power supply and the battery should be connected.

Automatic autonomous test

The Automatic autonomous test is conducted and measures the device's back up operation and emergency duration. This test is conducted automatically every 6 months. In order to be performed, the mains power supply and the battery should be connected and fully charged. If the battery is not fully charged, the test is postponed until the battery is completely charged. If during this test, the autonomy is less than nominal then the LED battery fault will permanently be on and the battery must be replaced.

Back up operation

The autonomous duration of battery during emergency mode is at least the one that is stated in the list of the technical characteristics. During emergency mode, a light source test is also performed.

Resetting errors

Push the test button for more than 10 seconds, to delete all the LED indicated errors. Then the device enters regular operation mode.

Changing the operating mode

The control of maintained or non maintained operation of the luminaire is achieved through Switch 4 of DS1. For maintained operation, switch number 4 must be in ON position. For non-maintained operation, switch number 4 must be in OFF position according to the step 5 in page 3.

ATTENTION!!!

- Operations for installation, maintenance or testing must be done by authorized personnel only.
- The device must be connected to the mains power supply through a fuse that is dependent on the total line's power load.
- In case of battery replacement, this must be replaced by part of the same type, by the manufacturer or by a competent person.
- In case of inactive use for a period greater than 2 months, disconnect the battery by pulling out the battery's connector.

5. It is not allowed to discard batteries into common trash bins, they must be discarded only in battery recycling points. Do not incinerate.



Indications LED Status

CHARGE (green)	BATT. FAULT (yellow)	LAMP FAULT (red)	Description
●	∅	∅	Battery fully charged
●	∅	∅	Charging
○	∅	∅	Faulty battery (When not in emergency)
∅	∅	●	Faulty LED
∅	∅	○	LED OK
∅	∅	●	LED test
∅	○	∅	Battery OK
∅	●	∅	Battery test
●	●	∅	Battery autonomy fault

Note:
 ● : Permanently ON
 ○ : OFF
 ● : Blinks
 ∅ : Indifferent

Installation methods

Luminaire disassembly

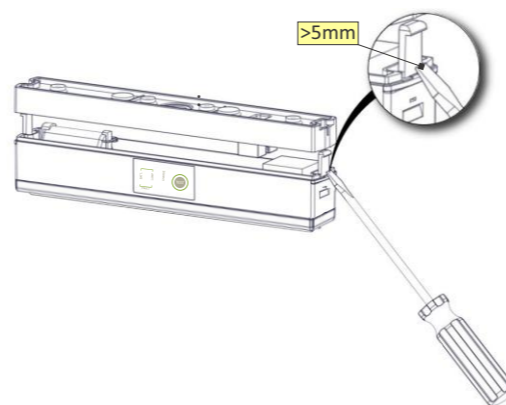

Wall mounting

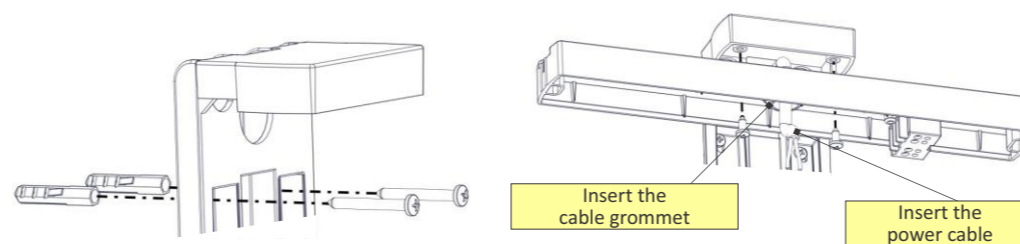

Hanging installation

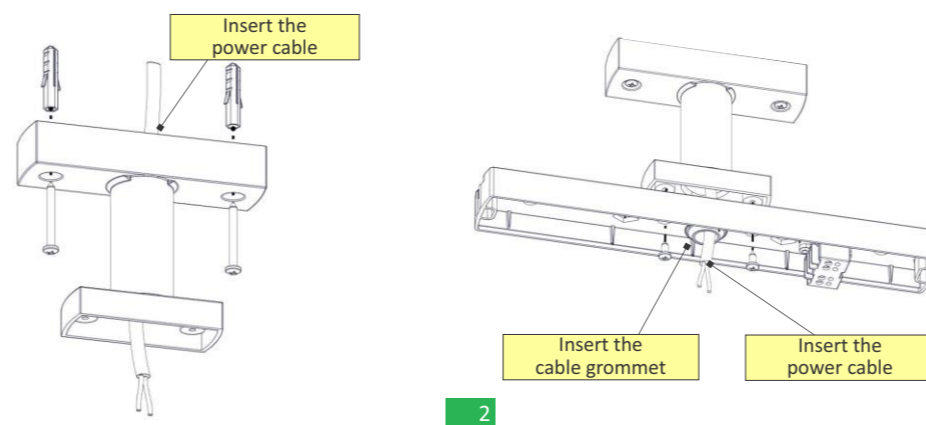

Ceiling mounting

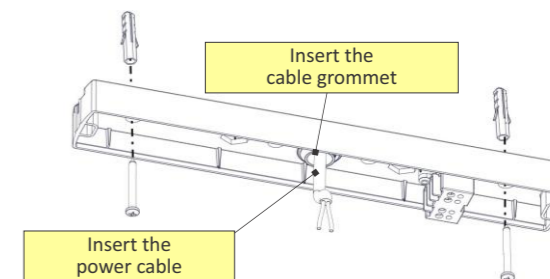

After the desired installation follow the steps below

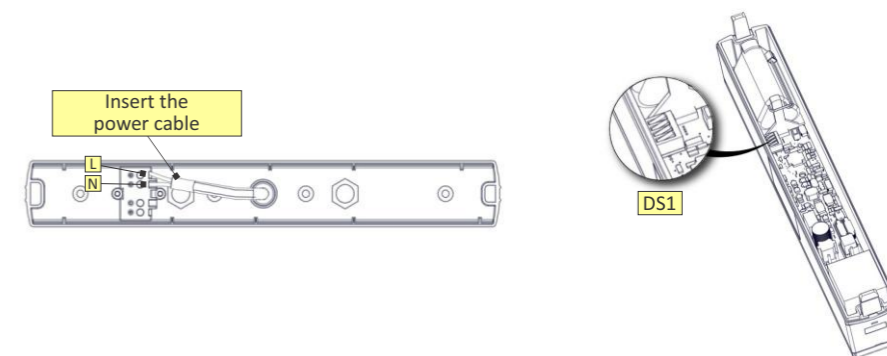

3

4



Maintained operation



1h



3h (default position)



Non-maintained operation

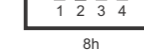

8h

Luminaire assembly

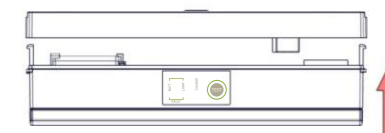

5

6

Accessories for installation (After request)

- A-2130: Accessory for ceiling (1m)
- A-2131: Accessory for ceiling (0,5m)
- A-2132: Accessory for ceiling (0,25m)
- A-2133: Accessory for wall mounting
- A-2136: Accessory for hanging installation (2,5m)

Battery replacement

- Disassemble the luminaire.
- Remove the battery connector and carefully remove the battery from its base.
- Install a new battery of the same type and rating.
- Assemble the luminaire and power the device.